

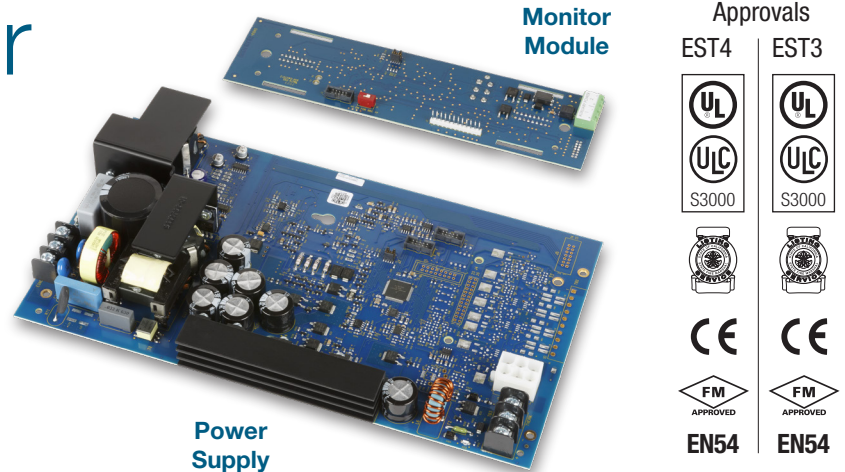

System Power Supplies

4-PPS/M series



Overview

System power supplies consist of two assemblies, a high efficiency switch mode power supply card and a power supply monitor module. The monitor module mounts to the local rail and distributes the power from its supply to the local rail. The local rail distributes power from all power supplies to other local rail modules and user interface cards resulting in “Shared Power” throughout the system. The 4-PPS/M can be configured as a primary power supply (PPS), booster power supply (BPS), or booster charger (BBC).

A 4-PPS/M configured as the PPS provides filtered, regulated power to the rail chassis modules as well as 24 VDC for operating ancillary equipment. The PPS consists of a power supply unit (PSU) mainboard and a monitor (MON) module.

Each booster power supply consists of the PSU mainboard and MON module. The booster power supply MON module provides the interface between the booster and the panel, making the required data and power connections to and from the rail chassis.

Maximum use of available power is achieved by configuring the power supplies in parallel. This results in a potential reduction in the number of power supplies necessary to meet requirements.

As many as four power supplies combined in a single enclosure provide up to 28 amps of available power. Battery backup is provided using one to four sets of batteries, depending on standby power requirements.

System power supplies mount to the back of the chassis units or wallboxes. Access to auxiliary power is via easily accessible terminal blocks located on the power supply monitor module. Each power supply produces 7 Amps of filtered and regulated power.

With four power supplies located in an enclosure (one primary and three booster power supplies) 28 amps of current is available for local rail modules, control display modules and the eight auxiliary 3.5 amp power outputs (two per supply).

Standard Features

- High efficiency switch mode
- Increased power distribution efficiency - power supplies parallel allowing up to 28 amps in a single node
- Universal 120 to 240 VAC Operation
- 7 AMP filtered and regulated
- Two 3.5 AMP outputs
- Temperature compensated, dual rated battery charger
- Electronic power limiting
- Automatic load testing of batteries
- Fully approved to UL/ULC and EN54 standards

Application

The primary power supply provides the system with battery charging and voltage regulation. Software configures the charger to either 10-24 AH batteries or 30-65 AH batteries and controls the high/low charge rates. Batteries mounted in the same enclosure as the power supply, have their charge rate monitored and adjusted based on the local enclosure temperature, keeping charging rates within battery specification. For remote batteries a temperature probe is monitored in the remote battery cabinet and charge rates are adjusted automatically. Battery damage is unlikely to occur when environmental short term conditions are outside of normal operating ranges.

The 4-PPS power supplies automatically load test batteries by shutting down the battery charger and placing a load across the battery. If the battery voltage is outside the specification range the power supply reports a trouble. The trouble clears if the battery is able to recover and pass future load tests.

Battery leads are electronically short circuit protected. If a short occurs in the battery leads the charger automatically disables itself and causes a trouble. The system will constantly look to see if the short has cleared. If the short clears, the system automatically restores.

During operation on standby batteries, battery voltage is constantly monitored. A trouble is reported if the battery voltage falls below a specified value.

4-PPS power supplies provide specific information back to the CPU designed to help speed trouble shooting of system functions. Should a power supply detect a fault, specific diagnostic codes are available to speed trouble shooting. The LCD will display the power supplies address, a specific trouble code, and a text message describing the specific trouble. Text messages are easy to understand and include items like: Battery Trouble, Aux Power Overload Circuit 1, Aux Power Overload Circuit 2.

Engineering Specification

The fire alarm power supplies must be capable of being paralleled and to load share. Multiple power supplies must be capable of being backed up with a single 24 volt battery set. Each power supply shall be capable of charging up to 65 AH batteries. The power supply must be able to perform an automatic load test of batteries and return a trouble if the batteries fall outside a predetermined range. Power supplies must incorporate the ability to adjust the charge rate of batteries based on ambient temperatures. It shall be possible to adjust for ambient temperature changes in local cabinets as well as remote cabinets.

Installation and Mounting

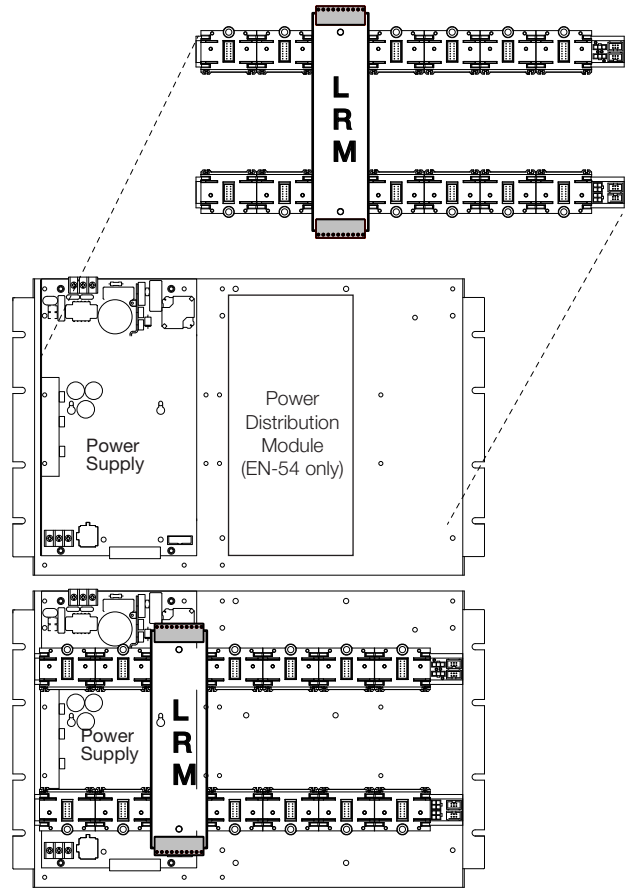

Power Supply Rules

- Equipment damage:** Do not install the 4-PPS/M in the same cabinet as a 3-PPS/M, 3-BPS/M, or 3-BBC/M. Combining the 4-PPS/M with legacy power supplies will cause damage to the power supply.
 - Each battery set needs one charger.
 - Each power supply must be connected to a battery set using an identical length and gauge of wire to keep voltage drops identical.
 - Distribute power supplies and loads evenly across rails.
 - All battery sets for a panel must be the same capacity (AH), same manufacturer, and same manufacturing date code.**
- The Table below illustrates the combinations of power supplies and batteries that meet all the power supply rules.

24 VDC Power Supply Output Current

	7A	14A	21A	28A
Battery Requirements	One Set, 65 AH max	Two Identical Sets, 65 AH max	Three Identical Sets, 65 AH max	Four Identical Sets, 65 AH max
Required 4-PPS/M Modules	1	2	3	4

Typical Wiring

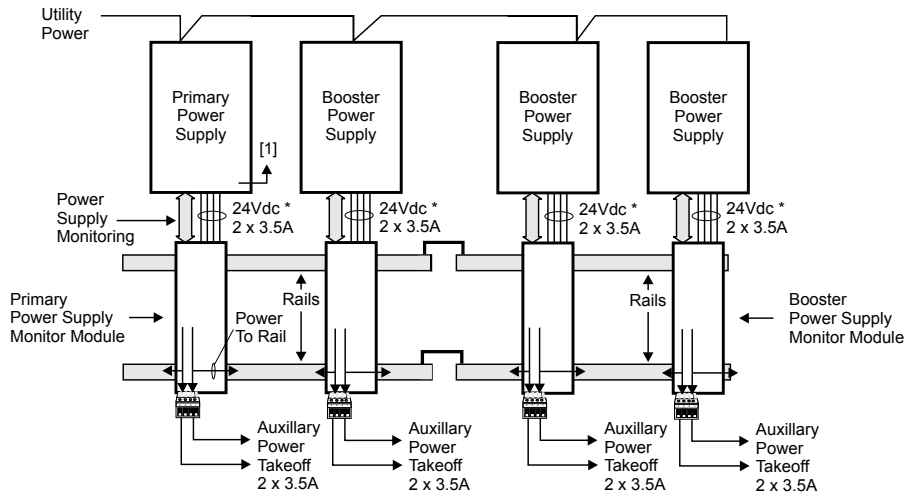

[1] From battery temperature probe terminals.

* Nominal Voltage

Specifications

Catalog Number	4-PPS/M and 4-PPS-M-E
Agency Approvals	UL, ULC, CE, EN54
Input Voltage	4-PPS-M: 120-240 Vac (+10%, -15%), 50-60 Hz 4-PPS-M-E: 120-230 VAC, +10%, -15%, 3.0 A, 50 to 60 Hz
Brownout Level	< or = 99 Vac
Current Requirements	PPS Included with CPU current requirements BPS/BBC Alarm: 45mA; Standby: 45mA
Input Current	3.0 A
Total Output	Special applications Total Internal DC Auxiliary DC*
Battery Charging Capacity	65 AH Sealed Lead-Acid
Low Battery Trouble	22.5 Vdc
Deep Discharge Cutoff	19.5 Vdc
Mounting Requirements	1 LRM space, 1 chassis footprint
Wire size (TB1 and TB3)	12 AWG to 20 AWG (4.0 mm ² to 0.75 mm ²)
Output Protection	Electronic power limiting & heat sink temperature
Ground Fault Detection	< 10K Ohms

*Regulated applications Total Auxiliary DC 24 VDC at 7.0 A (internal and auxiliary outputs) 24 VDC at 7.0 A max. Two 24 VDC at 3.5 A max. Power-limited and supervised for ground faults and shorts For special applications, see the panel compatibility list. 24 VDC at 4.5 A (internal and auxiliary outputs) Two: One 24 VDC at 3.5 A maximum for all circuits except the regulated NAC; one 24 VDC at 1.0 A max. for regulated NACs to 3-IDC8/4 modules only Power-limited and supervised for ground faults and shorts



Contact us

Phone: 800-655-4497 (Option 4)
 Email: edwards.fire@kgsolutions.com
 Website: edwardsfiresafety.com

8985 Town Center Pkwy
 Bradenton, FL 34202

©2025 Walter Kidde Portable Equipment, LLC.
 All Rights Reserved.

Ordering Information

Catalog Number	Description	Ship Wt., lb. (kg)
4-PPS/M	Primary Power Supply w/ local rail module 120-240V 50/60 Hz	5 (2.3)
4-PPS/M-E	Primary Power Supply w/ local rail module 120-230V 50/60 Hz, EN54 Certified, CE	5 (2.3)
3-BTSEN	Distribution Module required when battery installed in remote cabinet	.5 (.22)
3-BTSEN-E	Distribution module required when battery installed in a remote cabinet, (See EST4 European Marketplace Manual for wiring instructions)	.5 (.22)
4-FIL	Blank EST4 filler plate (order separately when no LED or LED/Switch module is installed on the inner door) For use in EN54/UL/ULC markets	0.1 (0.05)
3-FP	Filler Plate, order separately when no LED or LED/Switch module installed. For use in EN54/UL/ULC markets	0.1 (0.05)
3-PPSKIT	Power supply distribution board required with EST3 systems	5 (2.27)
4-PPSKIT	Power supply distribution board required with EST4 systems (See EST4 European Marketplace Manual for wiring instructions)	6 (2.7)
3-FR8	Ferrite kit includes 8 ferrites for EN54 applications, (See EST4 European Marketplace Manual for wiring instructions)	1.5 (.68)
4-FERKIT1	FERKIT1 Ferrite kit includes 1 ferrite required for EN54 applications, (See EST4 European Marketplace Manual for wiring instructions)	1 (.45)
4-FERKIT2S	Ferrite kit includes 2 small ferrites required for EN54 applications, (See EST4 European Marketplace Manual for wiring instructions)	0.5 (.23)
4-FERKITS2L	Ferrite kit includes 2 large ferrite kits required for EN54 applications, (See EST4 European Marketplace Manual for wiring instructions)	1 (.45)
4-PWRDIST	PWR DSTRIBUTION,EMI FLTR BD, required for EN54 applications, (See EST4 European Marketplace Manual for wiring instructions)	2 (.90)