



# Fire Alarm Bells



MEA



S218,  
S2202



7136-1657:  
0150

## Overview

EDWARDS Fire Alarm Bells are specially designed for fire alarm applications. The gongs are made of selected alloy steel to give the loud, resonant tones necessary in fire alarm systems.

Two gong sizes are available to overcome different ambient noise level.

The Fire Alarm Bells are of the underdome type with heavy duty mechanisms. Each bell is supplied with a mounting plate that fits any standard single-gang opening (see Installation Data). For weather-proof application EDWARDS offers an optional surface weatherproof back box. Refer to the Specification chart for applicability and catalog number of the weatherproof back box for the respective bell.

**Finish** — Standard gong and housing furnished gray with red label. Optional red finish available. **Add Suffix “R” to Catalog Number.**

**FM** — 438 and 439 Series Bells shown below are FM approved.

## Standard Features

- Vibrating and single stroke
- 6 inch (150mm), 8 inch (200mm), 10 inch (250mm) sizes
- Red or gray finish
- Rugged compact mechanism
- Heavy duty cast housing
- Low power drain
- Wide voltage selection
- Indoor or weatherproof



**Contact us**

Phone: 800-655-4497 (Option 4)  
 Email: [edwards.fire@kgsolutions.com](mailto:edwards.fire@kgsolutions.com)  
 Website: [edwardsfiresafety.com](http://edwardsfiresafety.com)

8985 Town Center Pkwy  
 Bradenton, FL 34202

©2025 Walter Kidde Portable Equipment, LLC.  
 All Rights Reserved.

## Installation

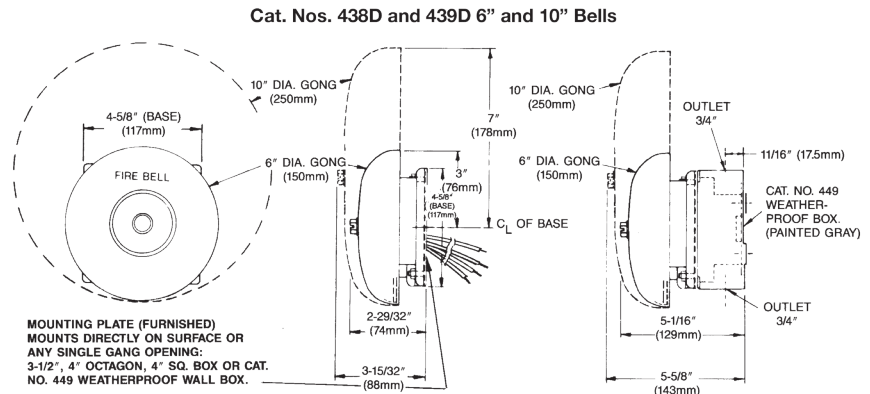

**Cat. Nos. 323D and 10" (254mm) Bells**

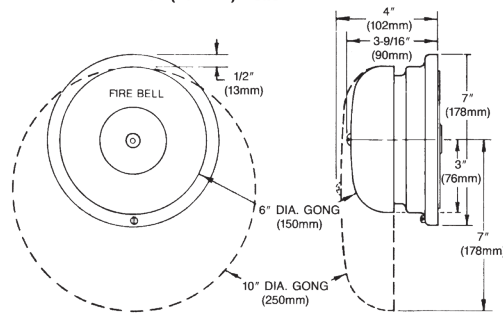

**WARNING:** These devices will not operate without electrical power. As fires frequently cause power interruptions, we suggest you discuss further safeguards with your local fire protection specialist.

EDWARDS recommends that these Fire Alarm Bells always be installed in accordance with the latest recognized editions of national and local codes.

## Specifications & Ordering Information

Cat. No.	DB @ 10 ft	Description	Volts	Amps	Weatherproof Box
323D-10AW-R	79	10" (250mm) Single Stroke, Diode	20-24 Vdc	0.33	N/A
438D-6N5-R	76	6" (150mm) Vibrating, Diode	120 Vac	0.034	449
438D-10N5-R	88	10" (250mm) Vibrating, Diode	120 Vac	0.034	449
439D-6AW-R	83	6" (150mm) Vibrating, Diode	20-24 Vdc	0.085	449
439D-10AW-R	86	10" (250mm) Vibrating, Diode	20-24 Vdc	0.085	449
438D-8N5-R	86	8" (200mm) Vibrating, Diode	120 Vac	0.034	449
439D-8AW-R	84	8" (200mm) Vibrating, Diode	20-24 Vdc	0.085	449
439D-6AWC	83	6" (150mm) Vibrating, Diode, Red, ULC listed	20-24 Vdc	0.085	449
439D-10AWC	86	10" (250mm) Vibrating, Diode, Red, ULC listed	20-24 Vdc	0.085	449

**Mounting Accessories**

449	Weatherproof surface mount box, grey. C/w gasket.
-----	---